

Denver Vibrator

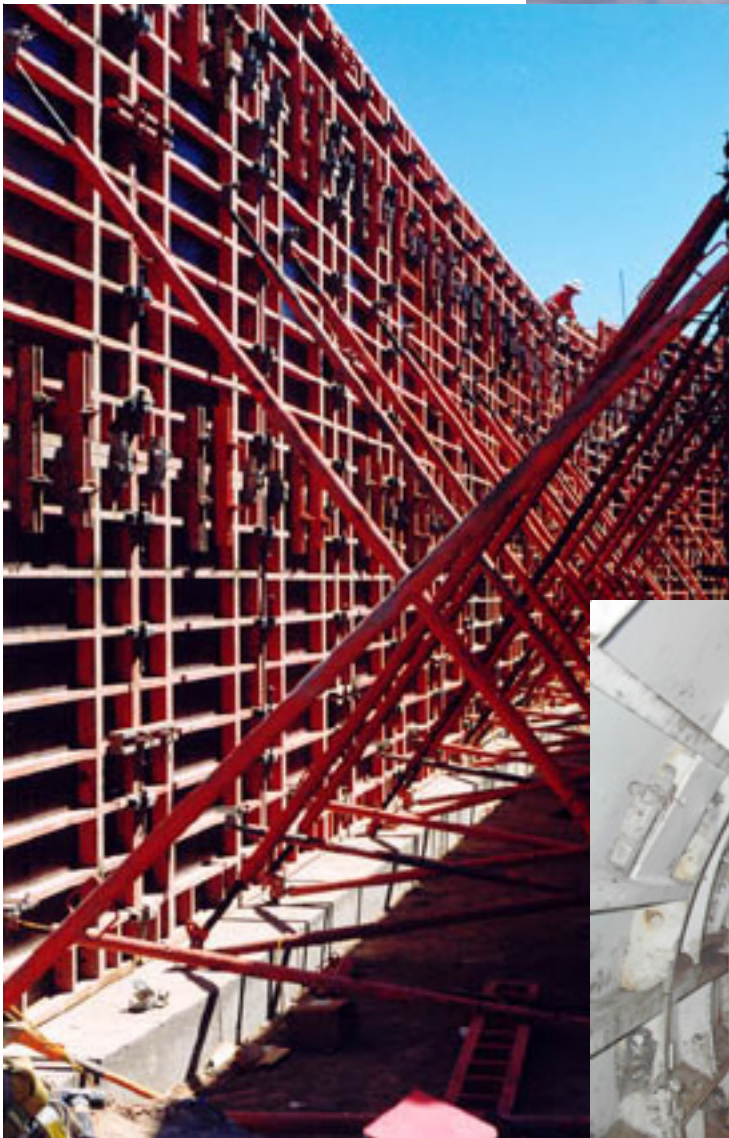

External Form Vibrators



Denver Concrete Vibrator 1463 W. Alameda Ave. Denver, CO 80223 USA
Toll Free: 800.392.6703 Tel: 303.778.8832 Fax: 303.778.8682
Web Site: www.denverconcretevibrator.com Email: info@denverconcretevibrator.com

Denver Vibrator

DTV Series Turbine Vibrator

- Extremely Effective for Concrete Consolidation
- More Efficient Than Roller Vibrators
- Will Work in Any Position
- No Lubrication Needed
- High Tolerance for Dirty Air
- Cylindrical Roller Bearings for an Extra Long Life



Model DTV7-3 vibrator with a TVMC clamp-on bracket on a staircase form.

Turbine Vibrator Performance and Dimensions

Performance Data	AIR PRESSURE								
	40			60			80		
VIBRATOR MODEL	Speed RPM	Flow CFM	Force LBS	Speed RPM	Flow CFM	Force LBS	Speed RPM	Flow CFM	Force LBS
DTV7-1	11,000	30	1,263	13,000	40	1,764	14,000	50	2,046
DTV7-2	11,000	30	1,804	13,000	40	2,520	14,000	50	2,922
DTV7-3	11,000	30	2,577	13,000	40	3,600	14,000	50	4,175

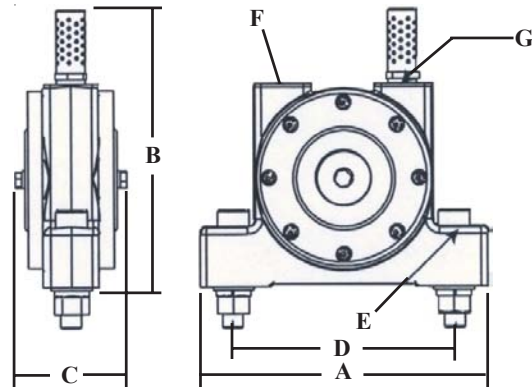
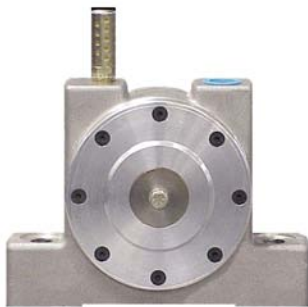

Dimensional Data	A	B	C	D	E	F	G	Weight
All Models	10.5"	7.5"	3.5"	8"	13/16"	1/2" NPT	3/4" NPT	13.5 lbs

Denver Vibrator P.O. Box 27790 Denver, CO 80227-0790

Toll Free: 800-392-6703 Ph: 303-778-8832 Fax:303-778-8682

Web: denverconcretevibrator.com

Looking for an electric vibrator option to air? See our High Speed Electric catalog.



DUAL ROLLER VIBRATOR

The DHFR dual roller series portable vibrators are ideal for applications which respond well to high frequency, adjustable rotary vibration. In applications such as placing refractory and other lining materials, concrete or similar materials, Denver's dual roller vibrators shorten pouring time, speed consolidation and increase compaction. The DHFR Series of vibrators are also ideal for bins, hoppers, railcars, chutes and screens.



Denver's DHFR vibrators are lightweight, easy to handle, and quickly installed. In operation, air pressure activates the rollers (one within the other), creating multiple vibrations during each orbit. Motorless and bearingless, the DHFR series of vibrators are designed for a long life of heavy duty service in the harshest of conditions and require very little maintenance. With the availability of a variety of brackets and accessories, Denver Vibrator's dual roller series is one of the most versatile vibrators available.

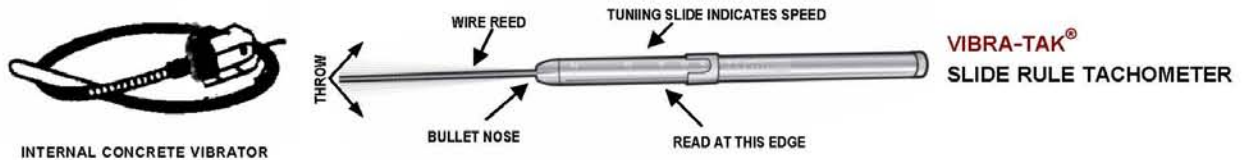

MODEL	Weight Lbs.	Minimum Hose ID	Unbalance	30 PSI			60 PSI			90 PSI		
				Speed VPM	Force Lbs	CFM	Speed VPM	Force Lbs	CFM	Speed VPM	Force Lbs	CFM
DHFR-4400	16	5/8"	0.6	6000	960	39	9000	2100	60	11000	3200	68
DHFR-5500	37	3/4"	1.6	5000	1700	30	7000	3500	49	9000	5700	58
DHFR-6500	40	3/4"	3.3	3500	1800	32	5000	3700	44	7000	7100	52
DHFR-7800	38	3/4"	5.8	2000	1600	35	3000	4200	46	5500	8100	51

Selecting and Applying External Concrete Vibrators

Vibrating concrete is not an exact science. Many factors determine which external vibrators are needed, how they are applied and the quality of the finished concrete product. Please consider all of the following factors carefully when choosing and applying an external vibrator to your form. The guidelines below are only given as general “rules of thumb”. Feel free to contact the factory at 800.392.6703 if you have any questions or would like assistance in the selection process.

Selecting a Vibrator

Usually, concrete requires a very high frequency of vibration in order to remove air bubbles, mix the aggregate and provide a smooth, clean finish. Except when used for drycast concrete, the ideal speed of the vibrator should be in the 8,000 to 13,000 vibrations per minute (VPM) range. Most all of the vibrators on the market sold for concrete consolidation will operate in this range.

How Much Total Force is Needed

We start the sizing process by determining how much force is needed for the job. Vibrators are sized by both frequency (VPM or RPM) and force output. Concrete that is extremely stiff, or has a “low slump”, generally responds better to a vibrator with a lower frequency and higher force output. Wetter mixes, or those with a “high slump” usually respond better to higher frequency and lower force. Below (fig.1) is a general guide that will help determine how much total force is needed for a particular job:

Vibrator Force Requirements

Slump	Force needed
Less than 1/2"	2.5 pounds of vibrator force for every 1 pound of form and concrete weight
1/2" to 2"	1.5 pounds of vibrator force for every 1 pound of form and concrete weight
2" or greater	1 pound of vibrator force for every 1 pound of form and concrete weight



Roller vibrators on a wall for a water storage tank.

fig.1

Example:

In a single lift and run, you are going to pour a wall that is 20' long, 10' high and 6" thick. Lets assume that the form is steel and has an empty weight of 4,000 lbs. The concrete being poured has a 1" slump. How much total force would be needed for the pour?

We already know that the empty form weighs 4,000 lbs. Next, let's calculate the weight of the concrete that will be inside the form. To do this, we need to know the volume (in cubic feet) inside of the form:

$$20' \times 10' \times 6" = 100 \text{ cubic feet.}$$

For our example, our concrete weighs 150 pounds per cubic foot. Therefore, the total weight of concrete in the form is $150 \times 100 = 15,000$ lbs of concrete. Add the weight of the form of 4,000. $15,000 + 4,000$ and we get a total of 19,000 lbs of concrete and form weight.

Now, multiply the total weight by 1.5 (based on the rule above for concrete with a slump of 1/2" to 2"). $19,000 \text{ lbs} \times 1.5 = 28,500$ lbs. Therefore, the vibrators will need to produce a total of 28,500 force lbs.

How Many Vibrators are Needed

Next, we will need to figure the number of vibrators needed for a given application. This is done by determining the effective range the vibrator will have on your application. The effective range of a vibrator depends on several factors such as; wetness of the concrete, wood vs. metal form, how the vibrator is attached, etc... Generally, an external vibrator will have a radius of effect of 2.5 ft to 5 ft. Below is a chart (fig.2) that describes the typical radius of effect of a vibrator when it is attached using a good, rigid mount on a metal form.

Radius of Effect Chart

Slump	Radius of Effect	Space Between Vibrators
Less than 1.5"	3 feet	5 feet
1.5" - 2.5"	3.5 feet	6 feet
3.5" - 6"	4 feet	7 feet
Greater than 6"	5 feet	8 feet

fig.2



Continuing with our earlier example in which we calculated the need for 28,500 lbs of force; using the "Radius of Effect Chart" we can determine how many vibrators will be required for this application. Being that the slump in our example is 1", each vibrator will have an approximate radius of effect of 3 feet. When using multiple vibrators, you always want to make sure that one vibrator's radius of effect will overlap another vibrator's radius of effect to ensure proper coverage. Therefore, in our example, it is suggested that the vibrators be placed 5 feet apart. To calculate the number of vibrators, draw a rectangle (see fig.3) and place the 1st vibrator 2.5 feet from the left and 2.5 feet from the bottom on the lower left corner of the form (2.5 feet is half of the suggested space between the vibrators). Then draw another vibrator 5 feet to the right of the first. Continue adding a vibrator every 5 feet to the right until the last vibrator is within 2.5 feet from the right edge of the form. This is the number of vibrators that will be needed on the bottom row.



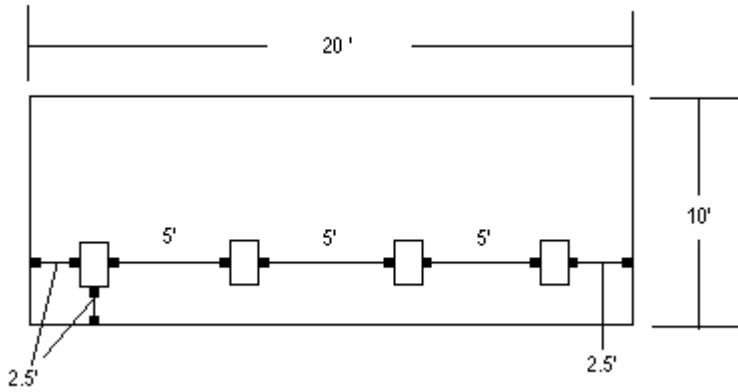

fig.3

Next, we will add an additional row above the bottom layer. Once again, in our example, we will come 2.5 feet from the left edge of the form. However, we should space the second row of vibrators 5 feet above the first row (fig.4) as this is the recommended spacing between based upon the "radius of effect chart". As in the first row, continue adding vibrators until the last vibrator is spaced within 2.5 feet of the right edge of the form.

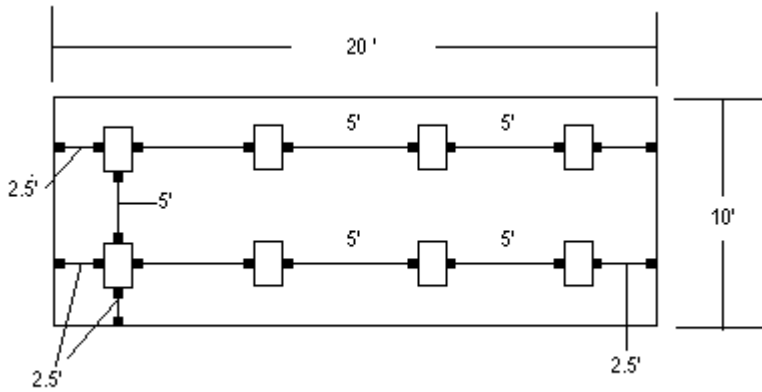

fig.4

With our current example, we see that we will need a total of 8 vibrators for this pour. If the form were taller than 10 feet, you would continue adding rows in the same pattern until the top row of vibrators are within 2.5 feet of the top of the form.



Which Vibrator is Right for My Job

Continuing with our example, we know that the job will need a total of 28,500 lbs of force. We also know that we will need a total of eight vibrators to ensure proper coverage. Next, we need to select which vibrator is right for the job by determining how much force each vibrator will need to produce. To get this number we divide the total needed force of 28,500 lbs of force by quantity of vibrators (8) needed: $28,500/8 = 3,562.50$ lbs of force. Based upon this information, each vibrator will need to produce approximately 3,563 lbs of force.

Referring to page 2, in the turbine vibrator performance data, we find that the model DTV7-3 produces approximately 3,600 lbs of force at 60 psi. Therefore, the model DTV7-3 would be a good model for our application. A total of eight DTV7-3's will be needed for our wall.

Portability

Often, brackets are used to move the vibrators as the concrete is being poured. The advantage of using brackets to make the vibrators portable is that you can usually do the job with fewer vibrators and, therefore, save money. Referring back to our original application where we needed a total of (8) DTV7-3's to pour our 20' x 10' x 6" wall. If we add a clamp-on bracket to the DTV7-3, we could reduce the total number of vibrators needed to 4. We would clamp this vibrator to the form in the same position as the first row in our example. Once the lower section has been vibrated, you would simply un-clamp the vibrators from the lower row and move them to the next higher position. If your form is tall enough where multiple rows of vibrators will be needed and you are pouring at a pace where you cannot move a single row of vibrators fast enough to keep up with the pour, then it is recommended that you get enough vibrators to make two complete rows and "leap frog" the lower vibrators as the pour continues. When using a "leap frog" pattern, make sure that the concrete has reached the upper level of vibrators and they are operating before the lower level of vibrators are turned-off and moved higher.

Denver Vibrator has a wide range of portable brackets available to fit almost any form. Please contact the factory at 800.392.6703 for more information.



Wood Clamp Bracket



CL/CC Bracket



Cradle Lug Bracket



Flange Mount CC Bracket



Turbine vibrator with a flange mount bracket on a staircase form.

Walls Greater Than 6" Thick.

When sizing and placing a vibrator, in addition to the "radius of effect" of the vibrator, you must also consider the penetration of the vibrator. On walls greater than 6", we recommend that you stagger the vibrators on opposite sides of the form. This will ensure that both sides of the pour will have a clean finish. (see fig.5 and fig.6 on the next page).



Denver Vibrator

How Long to Vibrate the Concrete

Vibrating concrete is more of an art than a science. The length of time that concrete should be vibrated can vary from a several seconds to several minutes. Variables such as; wetness of the pour, force and frequency of the vibrator, type of form used, the amount of rebar used, size of aggregate, how the vibrator is attached, etc... all play a role in how long concrete should be vibrated.

Typically, the best way to determine if the concrete has been vibrated enough is to visually inspect the concrete from above the form as it is being vibrated. When the vibrators are activated, the concrete will begin to churn and air bubbles can be seen escaping. When bubbles are no longer escaping and a creamy, shiny surface can be seen, the concrete has been vibrated enough (you may also hear a change in the pitch of the vibrator).

If you measure the length of time from vibrator start-up to the point where the concrete is consolidated (as described above) you can use the same length of time each time the vibrators are used as the pour continues. Please note that this length of time may vary from pour to pour or form to form. If the wetness of the mix, type of vibrator, type of form or method of mounting change during the pouring process, you will need to do another visual test and measure the time once again.

Do's and Don'ts

Do's:

- **Do wear a hardhat, safety glasses, ear protection, gloves and safety boots when working around vibrators on concrete forms.**
- Do start the first row of vibrators about 2 to 2.5 feet above the bottom of the form.
- Do make sure the form is structurally sound before pouring concrete and vibrating.
- Do make sure that the vibrators are securely attached to the form being vibrated.
- Do pre-mark, on the outside of the form, the areas where the vibrators will be placed before you start the pour. This will make it easier when moving vibrators from one location to another while the pour is in progress.
- Do make sure you have enough vibrators to do the job properly. Have backup vibrators on hand before starting the pour.
- Do use internal vibrators first, if both internal and external vibrators are being used. Use the external vibrators only when the internal vibrators have been removed or are at least few feet above where the externals are being operated.

Don'ts:

- Do not operate the vibrators on an empty form. Start the vibrators only when the level of the concrete is at or slightly above (6" – 12") the level of the vibrator being used. If necessary, mark the inside of the form to indicate where the vibrator on the outside is located.
- Do not "under vibrate". Too short of a vibration time will result in a poorly finished product. Under vibration is more common when low-slump mixes are used.
- Do not "over vibrate". Too long of a vibration time may cause separation. This is especially true when large aggregates are used in a high-slump mix.
- Do not space the vibrators too far apart. If the areas of effectiveness of the vibrators do not overlap, you may not get the desired results in the finished product.

